



LR-100 Stationary Receiver/Power Amplifier

***Don't miss a single sound.***





Dear Valued Customer,

Thank you for choosing Listen! All of us at Listen are dedicated to providing you with the highest quality products available. We take great pride in their outstanding performance because we care that you are completely satisfied. That's why we independently certify them to the highest quality standards and back them with a limited lifetime guarantee. We stand ready to answer any questions you might have during installation or in the operation of our products. Should you experience any problems whatsoever with your Listen products, we are ready to help you in any way we can with prompt, efficient customer care. Because at Listen, it's all about you! And should you have any comments on how we might improve our products or our service, we're here to listen.

Here's how to reach us:

+1.801.233.8992

+1.800.330.0891 North America

+1.801.233.8995 fax

[support@listentech.com](mailto:support@listentech.com)

[www.listentech.com](http://www.listentech.com)

Thank you and enjoy your listening experience!

Best regards,

Russell Gentner and the Listen Team

- In the few instances where repairs were needed, 99% of all clients indicated that they were happy with repair turn-around-times and 85% of the time, clients were without their product for less than 10 days!
- Overall client satisfaction of working with Listen was rated 4.8 out of 5.
- "Please continue with your excellent attitude toward customer satisfaction. You guys are great!"
- "I've never had such good service from any company. Keep up the good work!"
- "You stand behind your product wonderfully."



# LR-100 Table of Contents

---

Package Contents	3
Specifications	4
Architectural Specifications	4
Specifications	4
Quick Reference	6
Block Diagram	8
Setup Instructions	9
Installation	11
Speaker Connection	12
Antenna Installation	12
Programming	13
Squelch Adjustment	14
Listen SQ™	15
Channel Selection	16
RF Reception Maximization Strategies	17
Resetting After an Overload Condition	17
Coaxial Cable	18
72 MHz Frequency Compatibility Table	19
216 MHz Frequency Compatibility Table	20
Supplementary Information	21
Troubleshooting	21
Compliance Notice	22
FCC Statement	22
Warranty	23
Contacting Listen	23
Optional Accessories	24



# LR-100 Package Contents

---

## LR-100 Contents

- LR-100-072 (72 MHz) or
- LR-100-216 (216 MHz)
- 120 VAC Power Supply
- LA-123 90 Degree Helical Antenna (72 MHz) or
- LA-124 90 Degree Helical Antenna (216 MHz)
- Allen Wrench
- Warranty Card
- User Manual

## Listen Part Number

LR-100-072 (72 MHz)  
LR-100-216 (216 MHz)



## Optional Accessories

See page 22

# LR-100 Specifications

## Architectural Specifications

The FM stationary receiver - power amplifier (receiver) shall be capable of receiving on 57 wide and narrow band channels in the frequency ranges of either 72 MHz or 216 MHz. The receiver shall be programmable to electronically lock out unneeded channels. The device shall have an adjustable squelch with an LED indication. The frequency response of the device shall be within 3dB from 63 Hz to 15K Hz at 72 MHz, or within 3dB from 63 Hz to 10 kHz at 216 MHz. The signal to noise ratio shall be 80 dB or greater. The device will have an integrated power amplifier capable of driving an 8 ohm speaker. The device shall be rack mountable and shall have the capability of a remote antenna. The device shall incorporate an LCD display that indicates channel and RF signal strength. The Listen LR-100 is specified.

Specifications	LR-100-072	LT-800-216	
RF	RF Frequency Range	72.025 - 75.950 MHz	216.025 - 216.9875 MHz
	Number of Channels	57 (17 wide band, 40 narrow band)	57 (19 wide band, 38 narrow band)
	Frequency Accuracy	± .005% stability +32° to +122 °F (0° to +50 °C)	
	Sensitivity	.6uV typical, 1 uV maximum for 12dB SINAD	
	Optional Antennas	Various antennas available	
	Antenna	LA-123 90° Helical Antenna (72 MHz)	LA-124 90° Helical Antenna (216 MHz)
	Antenna Connector	BNC	
Compliance	FCC Part 15, Industry Canada	FCC Part 90, Industry Canada	
** All system specifications are wireless end-to-end			
Audio	System Frequency Response	50 Hz - 15 kHz (±3 dB)	50 Hz - 10 kHz (±3 dB)
	System Signal to Noise Ratio (A-Weighted)	80 dB SQ enabled, 60 dB SQ disabled	80 dB SQ enabled, 50 dB SQ disabled
	System Distortion	<2% total harmonic distortion (THD) at 80% deviation	
	Auxiliary Input to Output	25 Hz to 20 kHz (±3 dB) frequency response, SNR 80 dB, Distortion: <0.2%	
	Balanced Auxiliary Input	Rear panel, one (1) female XLR-1/4 in combo connector, balanced, 0 dBu nominal input level adjustable, +13 dBu maximum, impedance 600 ohm	
	Unbalanced Auxiliary Input	Rear panel, two (2) phono connectors, unbalanced, -10 dBu nominal input level adjustable, +7 dBu maximum, impedance 10k ohm	
	Balanced Output	Rear panel, one (1) male XLR, balanced, 0 dBu nominal output level, +16 dBu maximum, impedance 2k/10 Ohms (line/mic)	
	Unbalanced Output	Rear panel, two (2) phono connectors, unbalanced, -10 dBu nominal output level, +2 dBu maximum, impedance 2k ohm	
	Headphone Output (Monitor)	Front Panel, one (1) 3.5mm stereo connector, unbalanced, adjustable output level, +7 dBu maximum, impedance 10 ohm	
Speaker Output	Rear panel, one (1) detachable terminal block, bridged, adjustable output level, 15/10 watts (peak/RMS) continuous power with 4 ohm load		
Controls	Set-up Controls Front Panel (Behind Security Cover)	Power, test tone on/off, channel up/down, input levels, mix level, contour, monitor volume control	
	User Controls	Volume, channel UP/DOWN, SEEK (all controls except volume are lockable)	
	Set-up Controls Rear Panel	"Audio output select (RX Only, RX + AUX, RX or AUX), Speaker (Output, Aux), switchable balanced output level"	
	Remote Controls	Eight (8) position detachable terminal block, channel up, channel down, mute	
Programming	Unit can be programmed so that only desired channels are displayed to the user, channel selection can be locked by holding the SEEK button 5 seconds.		
Indicators	VU Meter	Four (4) LED (three green, one red)	
	Power	Indicated by a green LED when on (front panel)	
	RF Power	Indicated on the LCD (low, mid, high)	
	LCD Display	Channel designation, lock status, RF power level, programming (front panel)	
	Squelch	Green LED illuminates when the unit is squelched	
	Mute	Green LED illuminates when the output audio is muted	
Power	Power Supply Type	In line power supply, Listen part number LA-201	
	Power Supply Input	Input: 120 VAC, 60 Hz, 19 Watts	
	Power Supply Output	Output: 15 VAC, 1 Amp	
	Power Supply Connector	Output Connector: .02 in (5.0 mm) OD, .01 in. (2.5 mm) ID, barrel type	
	Power Supply Compliance	UL Listed	
	Optional Battery	12VDC, connected via terminal block	
	Optional Battery Charging	Trickle charge of optional 12VDC battery through terminal block connection	



Physical	Dimensions (H x W x D)	1.75 x 8.50 x 9.13 in. (4.5 x 21.5 x 23 cm)
	Color	Dark Grey with white silk screening
	Unit Weight	2.8 lbs. (1.3 kg)
	Unit Weight with LA-201 Power Supply	4.2 lbs. (1.9 kg)
	Shipping Weight	5.6 lbs. (2.5 kg)
	Rack Mounting	One (1) rack space height, 1/2 rack space wide, one (1) or two (2) receivers can be mounted in one rack space, optional rack mount (LA-326)
Environmental	Temperature - Operation	-10 °C (14 °F) to +40 °C (104 °F)
	Temperature - Storage	-20 °C (-4 °F) to +50 °C (122 °F)
	Humidity	0 to 95% Relative Humidity, non condensing
		Specifications are subject to change without notification

# LR-100 Quick Reference

## LR-100 Front Panel

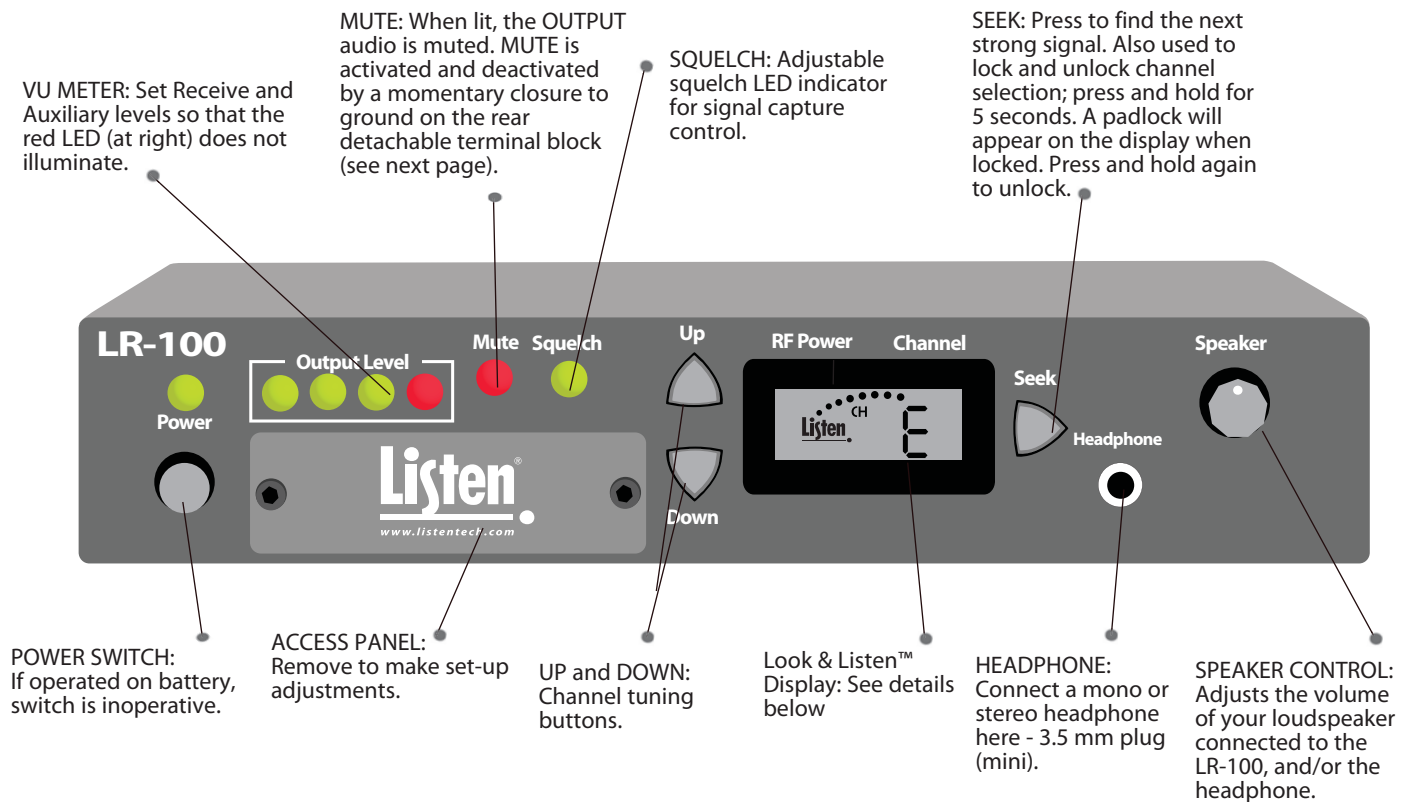

## LR-100 Behind Front Access Panel

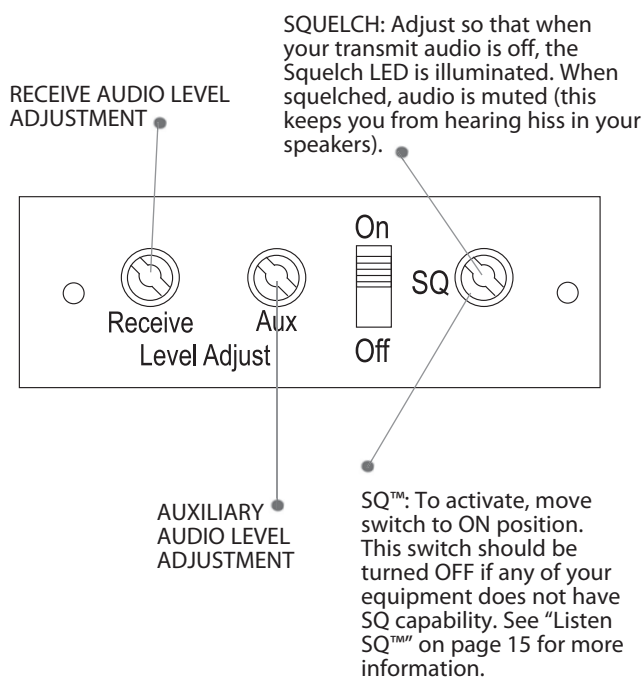

## LR-100 LCD Panel Details

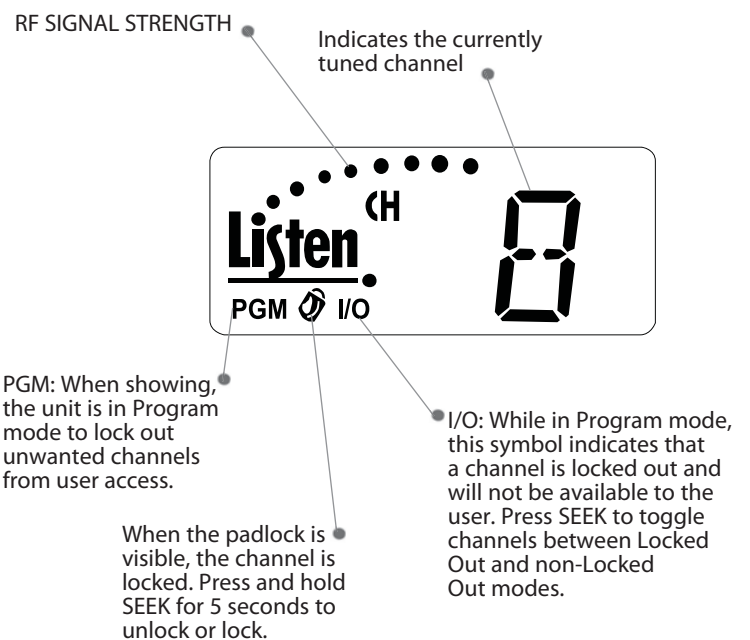

# LR-100 Quick Reference (cont.)

## LR-100 Rear Panel

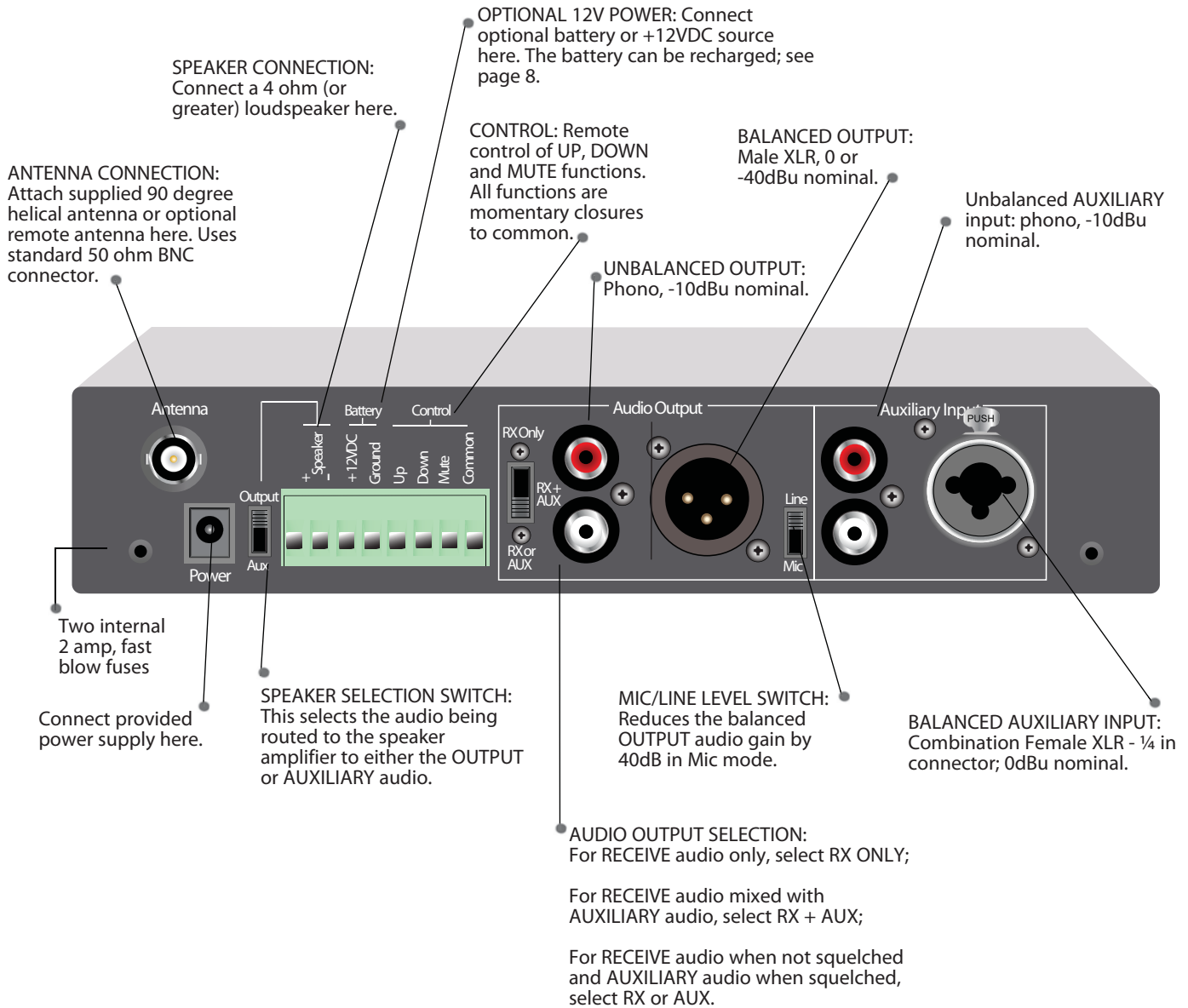

# LR-100 Block Diagram

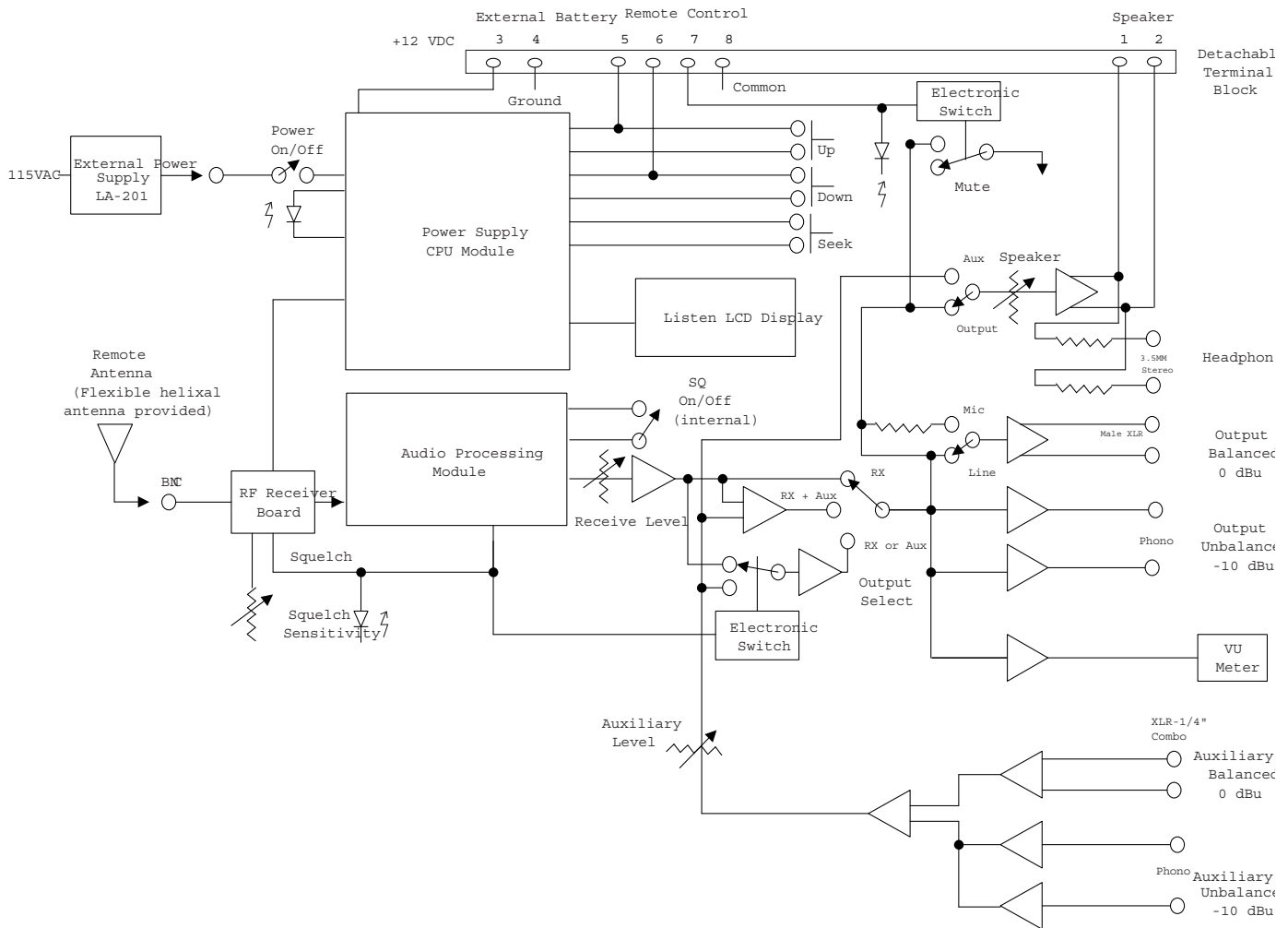

Quick Reference

# LR-100 Setup Instructions

## LR-100 Setup Instructions

- If you are using the LR-100's power amplifier, make sure the unit is given sufficient room around the ventilation holes.
- If you are rack mounting the LR-100, use the optional LA-326 rack mounting kit. This kit allows for single and dual rack mounting, and comes with a security cover.
- For mounting on vertical or horizontal surfaces, use the optional L bracket mounting kit, part number LA-327.

1

## Powering the Unit

**NOTE:** if the unit will not power up, see *Resetting After an Overload Condition*, page 17.

## AC Power Operation

The unit comes with a UL listed inline power supply designed for 115 VAC, 60 Hz operation. Do not use any other AC power supply. Use of any non-Listen supplied power supply will void the warranty. (Battery use is permitted; see below.) Plug the power supply into the back of the unit at the connector labeled POWER. Now connect the power supply to power.

## Battery Operation

To operate the unit on a battery or +12VDC power supply, connect to the rear detachable terminal block as follows:

1. Pin 3: +12VDC
2. Pin 4: Ground

**NOTE:** When operating on the +12VDC battery supply, the POWER switch is bypassed and the unit is always on.

You can optionally charge batteries by also supplying power to unit with the batteries connected. In this case, the batteries are trickle charged at a rate of 18 - 36 mA. You should only use rechargeable type batteries.

**CAUTION:** Attempting to charge non-rechargeable batteries may result in explosion and/or fire.

Detachable Terminal Block Wiring:

- Pin 1: Speaker +
- Pin 2: Speaker -
- Pin 3: Ground for Battery or Power Source connection
- Pin 4: +12VDC Battery or Power Source
- Pin 5: UP remote control function
- Pin 6: DOWN remote control function
- Pin 7: MUTE remote control function
- Pin 8: Common for remote control function

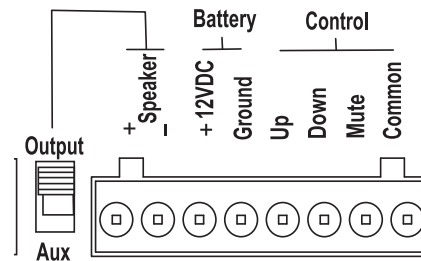

Installation - Audio Connections (See Quick Reference on pages 6-7.)

## OUTPUT Audio

The OUTPUT audio section is composed of an OUTPUT audio selection switch, a male XLR balanced audio OUTPUT connector and two phono unbalanced audio OUTPUT connectors.

## OUTPUT Audio Selection Switch

This switch selects what audio is routed to the OUTPUT audio connectors. The switch has three positions:

1. RX ONLY. In this position, only RECEIVE audio is routed to the OUTPUT. When the transmitter is turned off, the unit is squelched and the RECEIVE audio is muted.
2. RX + AUX. In this position, both the RECEIVE and AUXILIARY audio are mixed and routed to the OUTPUT.
3. RX or AUX. In this position, the OUTPUT audio is either RECEIVE or AUXILIARY audio. When the RECEIVE audio is squelched (indicated by the illumination of the SQUELCH LED on the front panel), AUXILIARY audio is routed to the OUTPUT. When RECEIVE audio is not squelched, RECEIVE audio is routed to the OUTPUT.

# LR-100 Setup Instructions (cont.)

---

## **Balanced Audio Output**

When connecting to the XLR balanced OUTPUT, use the pin out shown below. If the output is unbalanced, either use the unbalanced phono connectors or wire the balanced XLR output as shown below with pins 3 and 1 wired together. The OUTPUT audio has a nominal output level of 0dBu.

XLR pin out diagram for a balanced connection:

Pin 2 +

Pin 3 -

Pin 1 Shield

XLR pin out diagram for a unbalanced connection:

Pin 2 +

Pin 1 and 3 -

## **LINE/MIC Switch**

This switch reduces the OUTPUT level of the balanced OUTPUT audio only. It does not affect the OUTPUT level of the unbalanced audio. The OUTPUT audio is reduced by 40dB to microphone level when this switch is selected to MIC.

## **Unbalanced Audio Output**

There are two unbalanced phono audio OUTPUT connectors. The nominal OUTPUT audio level is -10dBu.

## **AUXILIARY Input**

The LR-100 has an AUXILIARY input that allows for greater functionality of the unit for a variety of applications. The AUXILIARY input consists of a balanced input, combination connector (female XLR and ¼ in) and two unbalanced phono connectors. All of these inputs are actively mixed together. Thus, any combination of input sources can be used. Input level is adjusted via the front panel trim pot labeled AUX LEVEL ADJUST. Adjust this level to fit the needs of your installation ensuring the last red LED on the VU meter is not illuminated (indicating peak audio).

## **AUXILIARY Balanced Audio Input**

The nominal input level for the balanced input is 0dBu.

Female XLR / ¼ in combination connector pin outs:

Pin 2 (tip) +

Pin 3 (ring) -

Pin 1 (sleeve) Shield

AUXILIARY Unbalanced Audio Input:

The nominal input level for the two unbalanced inputs is -10dBu.

Female XLR / ¼ in combination connector pin outs:

Pin 2 (tip) +

Pin 1 and 3 ring/sleeve

# LR-100 Installation - Audio Connections

---

## **OUTPUT Audio**

The OUTPUT audio section is composed of an OUTPUT audio selection switch, a male XLR balanced audio OUTPUT connector and two phono unbalanced audio OUTPUT connectors.

### **OUTPUT Audio Selection Switch**

This switch selects what audio is routed to the OUTPUT audio connectors. The switch has three positions:

- 1 RX ONLY. In this position, only RECEIVE audio is routed to the OUTPUT. When the transmitter is turned off, the unit is squelched and the RECEIVE audio is muted.
- 2 RX + AUX. In this position, both the RECEIVE and AUXILIARY audio are mixed and routed to the OUTPUT.
- 3 RX or AUX. In this position, the OUTPUT audio is either RECEIVE or AUXILIARY audio. When the RECEIVE audio is squelched (indicated by the illumination of the SQUELCH LED on the front panel), AUXILIARY audio is routed to the OUTPUT. When RECEIVE audio is not squelched, RECEIVE audio is routed to the OUTPUT.

### **Balanced Audio Output**

When connecting to the XLR balanced OUTPUT, use the pin out shown below. If the output is unbalanced, either use the unbalanced phono connectors or wire the balanced XLR output as shown below with pins 3 and 1 wired together. The OUTPUT audio has a nominal output level of 0 dBu.

XLR pin out diagram for a balanced connection:

Pin 2 +  
Pin 3 -  
Pin 1 Shield

XLR pin out diagram for an unbalanced connection:

Pin 2 +  
Pin 1 and 3 -  
LINE/MIC Switch

This switch reduces the OUTPUT level of the balanced OUTPUT audio only. It does not affect the OUTPUT level of the unbalanced audio. The OUTPUT audio is reduced by 40 dB to microphone level when this switch is selected to MIC.

### **AUXILIARY Unbalanced Audio Input**

The nominal input level for the two unbalanced inputs is -10 dBu.

Female XLR / ¼ in combination connector pin outs:

Pin 2 (tip) +  
Pin 1 and 3 ring/sleeve

# LR-100 Setup Instructions

---

## LR-100 Speaker Connection

4

The LR-100 contains a 44-watt (31 watt RMS), 4 ohm power amplifier.

The Speaker Selection switch determines what audio is directed to the power amplifier. With the switch in the OUTPUT position, the OUTPUT audio (same audio that is on the OUTPUT audio connectors) is directed to the power amplifier. With the switch in the AUX position, only AUXILIARY input audio is directed to the power amp. This allows you to use the power amp separate of the RECEIVER audio if desired.

**NOTE:** *When the speaker switch is in the OUTPUT position and the MUTE control is enabled (indicated by the illumination of MUTE LED), the speaker output is also muted.*

Connection to the speaker is achieved through pins 1 and 2 on the detachable terminal block. Strip the speaker wires, rotate the screws on the terminal block counter-clockwise, insert the wires and then tighten the screw clockwise until the wire is secure in the connector block. You may connect any parallel, series combination of speakers that produces an impedance of 4 ohms or greater.

EXAMPLE: If you have two 8 ohm speakers, you can connect these in parallel to produce a 4 ohm load to the power amp.

The SPEAKER level control on the front panel adjusts the level of the speaker.

The front panel headphone jack is in parallel with the speaker level. Connect any mono or stereo headphone to this 3.5 mm jack. Adjust level with the SPEAKER volume knob.

## LR-100 Antenna Installation

5

### Installation of Antenna

A properly installed antenna is critical to the operation of the LR-100. Without a strong and consistent RF signal from the transmitter, the LR-100 will not meet the needs of your installation. You can use the RF POWER indication on the LCD to provide a relative RF signal strength. You should see four or more dots displayed on the LCD for best results.

#### Using the supplied helical antenna

Connect the antenna to the rear BNC connector and orient the antenna vertically. If reception is from the transmitter is not adequate, consider using a remote antenna (see below) or place the LR-100 at an improved location to improve the signal strength. See RF Reception Maximization Strategies on page 17 for more information.

#### Using a remote antenna

For better reception in longer broadcast range applications, you should use a remote antenna. A remote antenna will allow you to get the antenna higher in altitude and in a position that is clear of obstructions. Please refer to the specific antennas instructions for installation. Also refer to Strategies for Maximizing RF Reception on page 17 for additional information.

**CAUTION:** *When installing antennas, ensure the antenna is clear of power lines.*

**NOTES:** *If the RF signal to the 216 MHz model is too high, the audio will be distorted. This may happen if the LR-100 is within 40 feet of the LT-800-216 transmitter. Consider reducing the output power of the transmitter or optionally removing the antenna on the LR-100 (there is sufficient internal antenna inside the LR-100 to receive an adequate signal from the transmitter).*



# LR-100 Programming

---

To make setup adjustments, remove the two hex screws that secure the front panel security cover.

## 1 **Setup VU Meter**

The front panel VU meter indicates the audio level of the OUTPUT signal. When making input audio level adjustments, ensure that the red LED does not illuminate.

## 2 **Input Audio Levels**

Proper adjustment of input levels is critical to the proper operation of the LR-100.

Receiver Audio Level Adjustment. Under normal audio conditions adjust the receive audio level to meet the output level needs of your installation. Make sure that the red LED on the VU meter does not illuminate.

Auxiliary Input Level Adjustment. Under normal audio conditions adjust the receive audio level to meet the output level needs of your installation. Make sure that the red LED on the VU meter does not illuminate.

## 3 **Selecting SQ ON or OFF**

See Listen SQ™ on page 15. If the transmitter that is broadcasting to the LR-100 is SQ capable, make sure the SQ switch for the transmitter and the LR-100 is turned ON. If not, the SQ switch should be turned OFF.

## 4 **Channel Selection**

Select the most appropriate channel by pressing the UP or DOWN button (see Channel Selection on page 16). You can also press the SEEK button and the unit will SEEK for the strongest RF signal. The unit may stop on a channel that is close to the actual broadcast channel, in which case the channel will sound noisy or distorted. Simply press SEEK again until you find the clearest operating channel.

To Lock Into Only One Channel: press and hold the SEEK button for 5+ seconds to lock a receiver into the currently tuned channel. Press and hold the button again to unlock.

**NOTE: It is highly recommended to lock the channel after installation to prevent accidental channel selection.**

## 5 **Programming**

In some cases, you may choose to give users the ability to select multiple channels. For example, let's say you are using the LR-100 for language interpretation. In this example, channels A, E and I are three different languages. You can use the LR-100 programming feature to lock out all but the three channels used in this example. By pressing the UP or DOWN button, the user can select between the three channels.

### **To Lock Out Channels in the LR-100:**

- Simultaneously press and hold the UP and DOWN buttons. You will notice the PGM indicator on the LCD indicating you are in the programming mode (the unit will go out of the programming mode if you don't press a key for 10 seconds).
- Use the UP and DOWN buttons to select the channels you want to lock out.
- As channels are displayed on the unit, those channels that are locked out from user access will be indicated by the L/O symbol on the display. When a channel is locked out, the LR-100 will skip over that channel when a user is tuning the unit. Press the SEEK button while in program mode to lock out a channel (lock out means the channel will NOT be displayed to the user). To reverse the lock out process, press the SEEK button on locked out channels.
- When you have completed programming the unit, don't press any key for 10 seconds and the unit will exit the programming mode.

# Squelch Adjustment

---

6

## **Squelch**

The squelch adjustment is important to ensure the receiver audio is muted when no signal is present. You want to set the squelch adjustment for the highest setting without squelching the incoming signal.

To set the squelch control:

Turn the transmitter OFF.

Listen to the receiver audio on the speaker or headphone. Turn the audio level down in the beginning.

Adjust the squelch adjustment clockwise until the squelch LED goes off (not illuminated). You will hear radio noise now. This is the audio you want to squelch (mute) when the transmitter is off.

Now adjust the squelch setting counter clockwise until it squelches (mutes). This is the minimum squelch setting.

Now turn the transmitter on. Adjust the squelch setting counter clockwise until the unit squelches. This is the maximum squelch threshold. Please note that if you are close to the transmitter, you may not be able to find the maximum squelch threshold due to the high RF signal of the transmitter.

Set the squelch adjustment between the maximum and minimum squelch thresholds, keeping the following in mind.

- Minimum squelch threshold. By adjusting the unit near this threshold, you will maximize the probability the unit will NOT squelch when the transmitter is on. However, you also run the risk having the unit NOT squelched (and resulting radio noise coming through the system) when the transmitter is off. You may experience unsquelching of the receiver by interference as well.
- Maximum squelch threshold. By adjusting the unit near this threshold, you will greatly increase the chance the unit will squelch when the transmitter is off AND you will minimize the probability that the unit will be unsquelched by interference. However, you are also increasing the chances that the signal coming from the transmitter will be squelched. Thus, if the RF signal from the transmitter dips just slightly (someone walks in front of the antenna), you will experience momentary squelching of the audio.

**CAUTION:** *Ensure proper setting of the squelch adjustment to prevent user ear damage and unwanted radio noise. Users will find unsquelched receiver noise very objectionable.*

# Listen SQ™ - Improving Your Listening Experience

---

We are accustomed to listening to low noise, high fidelity audio (delivered via CD, DVD, etc.). FM radio systems, such as those made by Listen, are inherently noisy compared to most sound systems. To reduce noise of our systems, Listen now offers a noise reduction technology called ListenSQ™. Both the transmitter and receiver must have SQ on to achieve the desired results. SQ is now available on new Listen systems, including the system you received in this shipment. If you are planning to use this product with older Listen systems or equipment not manufactured by Listen, you should disable SQ.

Your Listen equipment has been shipped to you with the SQ feature enabled. You may need to disable the SQ function for one or more of the following reasons:

- You are using your new Listen system with older version Listen equipment that does not have the SQ function.
- You are using your new Listen system with equipment supplied by other manufacturers.
- You expect that end users may bring and use their own receivers that don't have the SQ function.

## **SQ Summary**

- Improves noise performance by at least 20dB
- SQ is NOT compatible with older version Listen products
- SQ is NOT compatible with other manufacturers' products
- SQ is NOT squelch
- To work properly, SQ must be enabled for both the transmitter and receivers
- SQ can be disabled to permit operation with older Listen products or other manufacturers' products

# Channel Selection

---

It is highly recommended that after channel selection has been achieved, you lock the channel so that it cannot be changed by the user. To accomplish LOCK on the LR-100, press the SEEK button for 5 seconds. Repeat the process to unlock. It is important to choose channels that are free from interference to achieve proper operation of your Listen equipment. This process is trial and error. Before turning on the transmitter, listen to the wide band channels (lettered channels at 72 MHz and channels that start with a "2" for 216 MHz). Listen to the audio through the headphone or via the speaker. Choose a channel with the least amount of interference. Unless you are interfacing with an existing narrowband transmission system, always use a wide band channel. If you are using multiple channels follow this process:

- **Same Space.** If you are using transmitters in the same space, the most number of channels that will work simultaneously is six at 72 MHz and three at 216 MHz. With all of the transmitters off, listen for interference on all the wide band channels via the headphone jack on a Listen receiver. Using the frequency compatibility tables on pages 19-20, eliminate any channels that have noticeable interference. Now choose the channels with the widest channel spacing. It is recommended that adjacent channels be spaced at least 300 KHz. If there is no interference the following channels are recommended: A, C, E, I, J, and H for 72 MHz and channels 2A, 2K and 2V at 216 MHz.
- **Distributed Spacing.** If you are using transmitters that are spread out over space, you can achieve more simultaneous broadcast channels. However, it is critical that your receiver(s) be located as close to its transmitter as possible. You can use adjacent channels (see frequency compatibility tables on pages 13-14) in this case as long as the adjacent channel transmitter is at least 50% further away from the receiver as its transmitter. Example: The transmitter for the receiver on channel E is 100 feet from the receiver. The adjacent channel transmitter on channel D should be at least 150 feet away.

## **Notes in regard to using 72 MHz and 216 MHz systems:**

72 MHz is a secondary frequency band. This means that other transmitters are licensed to use these frequencies. Thus, you may experience interference from paging transmitters and other type transmissions. You will need to find a clear channel by listening to all the wide band channels.

216 MHz is a primary frequency band and no other types of transmissions are authorized to use it. Thus, you will find the highest probability of clear channels in this band. However, you may experience intermodulation of the TV Channel 13 aural carrier if there is a channel 13 transmitter in your area and you are close to the transmitter. If you cannot find a clear channel in 216 MHz band due to channel 13, it is recommended that you switch to a 72 MHz system.

# RF Reception Maximization Strategies

---

For proper and dependable operation, Listen receivers should receive a strong and consistent signal from the originating transmitter. The following strategies should be used to maximize this signal:

- 1 When designing and installing your system, keep in mind that the location of both the transmitting and receiving antennas is critical to maximizing signal strength.
- 2 Eliminate or minimize obstructions between the transmitting antenna and the receiving antenna.
- 3 Minimize the distance between the transmitting and receiving antennas.
- 4 Move transmitting and receiving antennas away from metal objects.
- 5 Place the transmitting antenna as high as possible.
- 6 Orient both transmitting and receiving antennas vertically.
- 7 For 216 MHz unit only, consider using a gain antenna such as a Yagi type antenna.

**CAUTION:** *When installing antennas, ensure the antenna is clear of power lines.*

**NOTE:** *If the RF signal to the 216 MHz models is too high, the audio will be distorted. This may happen if you are within 40 feet of the LT-800-216 transmitter.*

## Resetting After an Overload Condition

In an overload condition, the LR-100 will go into a protective state to protect the unit and power supply from excessive current and heat. This condition will occur if the speaker terminals are shorted to each other or if they are shorted to the chassis for over 15 seconds. In this condition, the LR-100 will no longer function normally. If the LR-100 stops functioning normally, do the following:

- 1 Turn the unit off and unplug it from power. If you are operating the LR-100 with an external +12VDC source such as a battery, disconnect the power source from the unit.
- 2 Remove the short to the speaker terminals.
- 3 Wait 30 seconds or longer.
- 4 Plug the unit back in and turn the power on.

The LR-100 should now function normally. If the unit is still not functioning normally, contact Listen Support.

# Coaxial Cable

---

The antenna for the LR-100 can be mounted directly on the unit if desired. However, you may find that the unit will provide better performance when the antenna is located elsewhere. If you plan to mount the antenna in a different location than on the top of the unit, you must use cable and connectors rated at 50 ohms. Although cable used for cable TV installations looks similar to this cable, it won't work with your Listen system.

If you need to run cable over a greater length than 50 feet for 216 MHz applications or greater than 100 feet for 72 MHz applications, we recommend that you use RG-8 cable rather than RG-58. It is a lower loss cable, meaning that more of your signal will reach the antenna.

Long cable runs can result in signal degradation due to "loss" characteristics of the cable. At 72 MHz, there is an average loss of 2 dB per 100 feet of cable and at 216 MHz an average\* loss of 5 dB per 100 feet of cable. (A 3 dB loss means half of your power has been lost.) However, it is better to suffer coaxial power loss than to try to shoot your signal through obstacles! Obstacles, especially metal, can create drop-outs or reflections of your signal that will result in poor listening conditions.

***\*Note: There are large varieties of 50 ohm, RG-58 and RG-8 cables. You may purchase a cable that is better or worse than this value. Please check with the cable vendor or manufacturer for exact specifications.***

# 72 MHz Compatibility Chart

Frequency MHz	Listen	Phonic Ear	Comtek	Phonak	Williams*	Gentner	Telex	Drake
72.0250	1	1	1	A1	(11, 1)			
72.0500					(2)	1		
72.0750	2	2	2	A2	(12, 3)			
72.1000	A	A	A	A	A, (13, 4)	2	A	72.1
72.1250	3	3	3	A3	(14, 5)			
72.1500					(6)	3		
72.1750	4	4	4	A4	(15, 7)			
72.2000	K	K	K	K	K, (8)	4	B	72.2
72.2250	5	5	5	K5	(16, 9)			
72.2500					(10)	5		
72.2750	6	6	6	K6	(17, 11)			
72.3000	B	B	B	B	B, (18, 12)	6	C	72.3
72.3250	7	7	7	B7	(19, 3)			
72.3500					(14)	7		
72.3750	8	8	8	B8	(20, 15)			
72.4000	N	N	N	N	N, (16)	8	D	72.4
72.4250	9	9	9	N9	(21, 17)			
72.4500					(18)	9		
72.4750	10	10	10	N0	(22, 19)			
72.5000	C	C	C	C	C, (23, 20)	10	E	72.5
72.5250	11	11	11	C1	(24, 21)			
72.5500					(22)	11		
72.5750	12	12	12	C2	(25, 33)			
72.6000	O	O	O	O	O, (24)	12	F	72.6
72.6250	13	13	13	O2	(26, 25)			
72.6500					(26)	13		
72.6750	14	14	14	4	(27)			
72.7000	D	D	D	D	D, (28)	14	G	72.7
72.7250	15	15	15	D5	(29)			
72.7500					(30)	15		
72.7750	16	16	16	D6	(30, 31)			
72.8000	P	P	P	P	P, (32)	16	H	72.8
72.8250	17	17	17	P7	(31, 33)			
72.8500					(34)	17		
72.8750	18	18	18	P8	(32, 35)			
72.9000	E	E	E	E	E, (33, 36)	18	I	72.9
72.9250	19	19	19	E9	(34, 37)			
72.9500					(38)	19		
72.9750	20	20	20	E0	(35, 39)			
74.6250	33	33	33	E3	(36, 40)			
74.6500					(41)	20		
74.6750	34	34	34	E4	(37, 42)			
74.7000	I	I	I	I	I, (38, 43)	21	O	
74.7250	35	35	35	I5	(39, 44)			
74.7500					(45)	22		
74.7750	36	36	36	I6	(40, 46)			
75.2250	37	37	37	I7	(41, 47)			
75.2500					(48)	23		
75.2750	38	38	38	I8	(42, 49)			
75.3000	J	J	J	J	J, (43, 50)	24	P	
75.3250	39	39	39	J9	(55, 51)			
75.3500					(52)	25		
75.3750	40	40	40	J0	(45, 53)			
75.4000	R	R	R	R	R, (54)	26		
74.4250	21	21	21	R1	(46, 55)			
75.4500					(56)	27		
75.4750	22	22	22	R2	(47, 57)			
75.5000	F	F	F	F	F, (48, 58)	28	J	75.5
75.5250	23	23	23	F3	(49, 59)			
75.5500					(60)	29		
75.5750	24	24	24	F4	(50, 61)			
75.6000	S	S	S	S	S, (62)	30	K	75.6
75.6250	25	25	25	S5	(51, 63)			
75.6500					(64)	31		
75.6750	26	26	26	S6	(52, 65)			
75.7000	G	G	G	G	G, (53, 66)	32	L	75.7
75.7250	27	27	27	G7	(54, 67)			
75.7500					(68)	33		
75.7750	28	28	28	G8	(55, 69)			
75.8000	T	T	T	T	T, (70)	34	M	75.8
75.8250	29	29	29	T9	(56, 71)			
75.8500					(72)	35		
75.8750	30	30	30	T0	(57, 73)			
75.9000	H	H	H	H	H, (58, 74)	36	N	75.9
75.9250	31	31	31	H1	(59, 75)			
75.9500					(76)	37		
75.9750	32	32	32	H2	(60, 77)			

\*Parenthesis indicate T35 and T20 narrowband.  
NOTE: Wideband frequencies in highlighted rows.

# 216 Compatibility Chart

Frequency MHz	Listen	Phonic Ear	Comtek	Phonak	Williams	Gentner	CSI	AVR	Light Speed
216.0125	1A		1	1				C01	N01
216.0250	2A	41	41	41		1	1		
216.0375	3A		2	2					
216.0625	1B		3	21					
216.0750	2B	42	42	42		2	10		
216.0875	3B		4	4					
216.1125	1C		5	5				C05	
216.1250	2C	43	43	43	A	3	6		
216.1375	3C		6	22					
216.1625	1D		7	23					
216.1750	2D	44	44	44	B	4	14		
216.1875	3D		8	8					
216.2125	1E		9	9				C09	N09
216.2250	2E	45	45	45	C	5	2		
216.2375	3E		10	24					
216.2625	1F		11	25					
216.2750	2F	46	46	46	D	6	11		
216.2875	3F		12	12				C12	N12
216.3125	1G		13	13					
216.3250	2G	47	47	47	E	7	7		
216.3375	3G		14	26					
216.3625	1H		15	27					
216.3750	2H	48	48	48	F	8	15		
216.3875	3H		16	16				C18	N18
216.4125	1J		17	17				C21	
216.4250	2J	49	49	49	G	9	18		
216.4375	3J		18	18					
216.5125	1K		21	61					
216.5250	2K	51	51	29	H	10	3		
216.5375	3K		22	62					
216.5625	1L		23	28					
216.5750	2L	52	52	52	I	11	12		
216.5875	3L		24	64				C24	N64
216.6125	1M		25	65				C25	
216.6250	2M	53	53	53	J	12	8		
216.6375	3M		26	81					
216.6625	1N		27	82					
216.6750	2N	54	54	54	K	13	16		
216.6875	3N		28	68					
216.7125	1P		29	69				C29	
216.7250	2P	55	55	55	L	14	19		
216.7375	3P		30	83					
216.7625	1R		31	84					
216.7750	2R	56	56	56		15	4		
216.7875	3R		32	72				C32	N72
216.8125	1S		33	73				C33	
216.8250	2S	57	57	57			13		
216.8375	3S		34	76					
216.8625	1T		35	85					
216.8750	2T	58	58	58			9		
216.8875	3T		36	86					
216.9125	1U		37	77				C37	N77
216.9250	2U	59	59	59			17		
216.9375	3U		38	88					
216.9625	1V		39	79				C39	
216.9750	2V	60	60	60			5		
216.9875	3V		40	80				C40	N80

**NOTE: Wideband frequencies in highlighted rows.**



## Troubleshooting

### ***The unit does not power up***

Ensure the power supply and/or battery is connected properly. Please note: this product no longer utilizes internal fuses. The fuses have been replaced with an automatic resetting device that automatically protects the unit in an overload condition. See Appendix F: Resetting After an Overload Condition for more details.

### ***The audio is muted occasionally.***

Check to see if the unit is squelching (indicated by the squelch LED). In this case, either improve the RF signal path or adjust the squelch setting for less squelch sensitivity (see page 14).

### ***I hear noise coming from the receiver (with my audio).***

You may have inadequate RF signal strength. Adjust the positioning of the antennas. Make sure the transmitter is on high power. You may be experiencing interference; try a different channel. Make sure the transmitter and receiver are on the same channel.

### ***The channel is often accidentally changed.***

Lock the unit on channel by pressing and holding the SEEK button for five seconds. The padlock symbol is illuminated on the LCD.

### ***There is no audio.***

Make sure the transmitter and the receiver are on the same frequency band (72 MHz or 216 MHz) and channel. Make sure the RECEIVE and/or AUX trim adjustments are turned clockwise. Make sure the unit is not MUTED, indicated by the MUTE LED. Make sure the unit is wired correctly. Make sure the squelch adjustment is set correctly.

### ***The audio is distorted.***

Make sure the transmitter and receiver are on the same channel. Make sure that the SQ switch is set the same way either ON or OFF for both the transmitter and receiver. Make sure the audio level is not set too high. For the 216 MHz version only, make sure you are not too close to the transmitter (within 40 feet).

### ***The OUTPUT level is low.***

Make sure the MIC/LINE switch is in LINE. Adjust the RECEIVE or AUX input levels.

### ***There is no audio on the speaker.***

Make sure the speaker selection switch is in the correct position. Ensure that you have a good speaker.

### ***I can't hear AUX audio on the OUTPUT.***

Move the OUTPUT audio selection switch to either "RX + AUX" or "RX or AUX" depending on your application.

### ***I cannot change channels.***

The unit is locked on channel (this is indicated by the padlock icon on the display). Press and hold the SEEK button for five seconds to toggle the lock off.

### ***The power switch does not work.***

This is normal when using the +12 VDC power on the rear terminal block.

If you are still having problems after checking the above items, call Listen for help. We are available from 8am to 5pm Mountain time, Monday through Friday, at 800.330.0891 or 801.233.8992, or you can e-mail us at [support@listentech.com](mailto:support@listentech.com). Our full contact information is available on page 24 of this manual.

# Compliance Notice & FCC Statement

---

## Compliance Notice

Listen's LR-100 Stationary Receiver / Power Amplifier

This device complies with part 15 of the FCC Rules. Operation is subject to the following two conditions: (1) These devices may not cause harmful interference, and (2) these devices must accept any interference received, including interference that may cause undesirable operation.

## FCC Statement

This equipment has been tested and found to comply with the limits for a class B digital device, pursuant to part 15 of the FCC Rules. These limits are designed to provide reasonable protection against harmful interference in a residential installation. This equipment generates, uses and can radiate radio frequency energy and if not installed and used in accordance with the instructions, may cause harmful interference to radio communications. However, there is no guarantee that interference will not occur in a particular installation. If this equipment does cause harmful interference to radio or television reception, which can be determined by turning the equipment off and on, the user is encouraged to try to correct the interference by one or more of the following measures:

- Reorient or relocate the receiving antenna.
- Increase the separation between the equipment and receiver.
- Connect the equipment into an outlet on a circuit different from that to which the receiver is connected.
- Consult the dealer or an experienced radio/TV technician for help.

This equipment has been certified to comply with the limits for a class B computing device, pursuant to FCC and IC Rules. In order to maintain compliance with FCC and IC regulations, shielded cables must be used with this equipment. Operation with non-approved equipment or unshielded cables is likely to result in interference to radio and TV reception. The user is cautioned that changes and modifications made to the equipment without the approval of manufacturer could void the user's authority to operate this equipment.

# Warranty & Contacting Listen

## Warranty

Listen Technologies Corporation (Listen) warrants its transmitters and receivers (LT-82, LT-700, LT-800, LR-100, LR-42, LR-44, LR-300, LR-400, LR-500, LR-600) to be free from defects in workmanship and material under normal use and conditions for the useful lifetime of the product from date of purchase.

Listen warrants its Stationary IR Radiators (LA-140) to be free from defects in workmanship and material under normal use and conditions for three years from the date of purchase.

Listen warrants its Noise Canceling Microphone (LA-270) to be free from defects in workmanship and material under normal use and conditions for one year from date of purchase.

All other products and accessories are warranted for 90 days from date of purchase.

This warranty is only available to the original end purchaser of the product and cannot be transferred. Warranty is only valid if warranty card has been returned within 90 days of purchase. This warranty is void if damage occurred because of misuse or if the product has been repaired or modified by anyone other than a factory authorized service technician. Warranty does not cover normal wear and tear on the product or any other physical damage unless the damage was the result of a manufacturing defect. Listen is not liable for consequential damages due to any failure of equipment to perform as intended. Listen shall bear no responsibility or obligation with respect to the manner of use of any equipment sold by it. Listen specifically disclaims and negates any warranty of merchantability or fitness of use of such equipment including, without limitation, any warranty that the use of such equipment for any purpose will comply with applicable laws and regulations. The terms of the warranty are governed by the laws of the state of Utah.

In the first ninety days after purchase, any defective product will be replaced with a new unit. After 90 days, Listen will, at its own discretion either repair or replace transmitters and receivers with a new unit or a unit of similar type and condition. Product that is not covered under warranty shall be repaired or replaced with a unit of similar type and condition based on a flat fee. Contact Listen for details.

This limited warranty, prices and the specifications of products are subject to change without notice.

## Contacting Listen

If technical service is needed, please contact Listen. Pre-authorization is required before returning Listen products. If products were damaged in shipment, please contact the carrier, then contact Listen for replacement or repair requirements payable by the carrier.

Listen's corporate headquarters are located in Salt Lake City, Utah U.S.A. and are open Monday through Friday, 8am to 5pm Mountain Time.

14912 Heritagecrest Way  
Bluffdale, Utah 84065-4818  
+1.801.233.8992  
+1.800.330.0891 North America  
+1.801.233.8995 Fax

support@listentech.com  
www.listentech.com

# Optional Accessories

## Antenna Accessories



LA-122  
Universal Antenna Kit  
(72 MHz and 216 MHz)

The single solution for all of your indoor remote antenna needs. Includes: 72 and 216 MHz components; flexible and rigid dipoles and monopole radials; hardware for multiple mounting configurations; and 25 ft. (7.6 m) of RG-58 coax cable.



LA-107  
Ground Plane Remote  
Antenna (216 MHz)

(Remote Mount, outdoor)



LA-125/LA-126  
Antenna Kit for Rack Mount  
(72 and 216 MHz)

LA-125 for 72 MHz  
LA-126 for 216 MHz

## LR-100 Rack Mount Accessories



LA-326  
Universal Rack Mounting Kit

Includes components for single and dual rack configuration and a security cover



LA-327  
"L" Bracket Mounting Kit for  
LT-800/LR-100/LT-82

Use to mount on any flat surface

## Optional Accessories



LA-316  
Expansion Speaker for  
LR-600 and LR-100



# *Notes*

---





Listen Technologies Corporation  
14912 Heritagecrest Way  
Bluffdale, Utah 84065-4818, U.S.A.  
+1.801.233.8992  
+1.800.330.0891 North America  
+1.801.233.8995 Fax

[www.listentech.com](http://www.listentech.com)